

Increasing RF device test throughput with better instrument coordination

Mary Anne Tupta, Keithley Instruments, Inc.

Increasing intelligence and programmability in test instruments can greatly accelerate component testing.

TESTING speed is important for all electronic components, but it is vital for low-price two- and three-terminal devices like diodes and transistors. Before RF tests can be conducted, the devices must be tested for DC operation. For diodes, that includes forward voltage, reverse breakdown voltage, and leakage current. For transistors, it includes the various junction breakdown voltages, junction leakage currents, DC beta (h_{fe}), collector or drain characteristics, etc. This article will show choosing the right test equipment and setting it up appropriately can greatly speed these tests.

Instrument Selection

While tests can be done by stacking up a collection of DMMs, voltage sources, and current sources, this takes up substantially more rack space than a system built with all these functions in one unit. There are multiple sets of commands to learn, and system programming and maintenance become complicated. On top of that, trigger timing becomes more complex and triggering uncertainty increases, while coordinating the

operation of separate instruments increases the amount of bus traffic required, again decreasing throughput.

The first part of the solution is to combine several functions in one instrument. A source-measure unit (SMU) combines a precision voltage source, a precision current source, a voltmeter, and an ammeter in one instrument, saving space and simplifying integration. The second part is to eliminate communication delays between the instruments and the control computer.

Minimizing Communications Overhead

When high-speed communications between instruments and computers became available it led to widespread automation of

test systems using a GPIB (IEEE-488 bus) link to deliver commands to control each step of a test. While this was a considerable advance over what went before, it has a significant speed penalty. GPIB, first off, has considerable communications overhead. The other disadvantage to GPIB for real-time test control comes from what's generally at the other end of the line: A PC running Windows®. Windows has significant and unpredictable latencies in responding to communications, which makes close synchronization of multiple instruments in the same test setup nearly impossible with the PC as sole controller.

The solution to this problem is to preconfigure the instruments using GPIB and then let them execute the tests themselves. Many of today's instruments have source memory list programming available, which allows up to 100 complete test sequences to be set up to run without PC intervention. Each test can contain different instrument configurations and test conditions, and can include source configurations, measurements, conditional branching, math functions, and pass/fail limit testing with binning capability. Some units can operate in DC mode or pulse mode with varying parameters and timing (integration, delays, etc.), making it possible to slow down more sensitive measurements and speed up others to optimize overall timing. With the instruments basically running themselves, the role of GPIB is to download the test program before the test and upload the results to the PC afterwards, neither of which interferes with the actual testing.

Instrument Triggering

To make a simple current-voltage (I-V) sweep, an SMU outputs a series of voltages while making corresponding current measurements while making corresponding current meas-

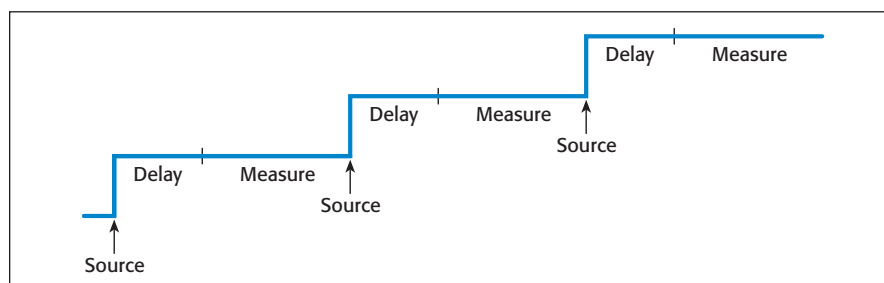

Figure 1: To make a current-voltage (I-V) sweep, the SMU outputs a series of voltages while making corresponding current measurements. At each voltage step, the SMU will first source a voltage. The voltage change in the circuit will induce a transient current, so using an appropriate amount of delay time between sourcing and measurement is critical to overall measurement integrity.

measurements (Figure 1). At each voltage step, the SMU will first source a voltage. The voltage change in the circuit will induce a transient current, so using an appropriate amount of delay time between sourcing and measurement is critical to overall measurement integrity. At different ranges, the instrument will adjust the delay time automatically to produce the optimal results. However, adding extra elements to the test circuit, such as long cables, a switch matrix, etc. will change the circuit's transient characteristics. Longer test times are usually necessary for high resistance devices. In these cases, additional delay time defined by the user will be needed to maintain the measurement integrity.

Testing Diodes

Our first example involves one test instrument, a device handler, and a PC. Note how the use of internal programming speeds up the test by eliminating most of the GPIB traffic.

Production testing of diodes involves a qualification step to determine the polarity of the diode under test, followed by measurements of forward voltage, reverse breakdown voltage, and leakage current (Figure 2). Forward voltage, V_F , is the voltage appearing across the diode at some specified value of forward current. It is measured by passing that value of current through the diode and measuring the voltage across it. Reverse breakdown voltage, V_{RM} or V_{BR} , is the value of reverse voltage at which current suddenly increases without limit. It is measured by forcing a specified reverse current and measuring the resulting voltage drop across the diode. The voltage reading is compared to

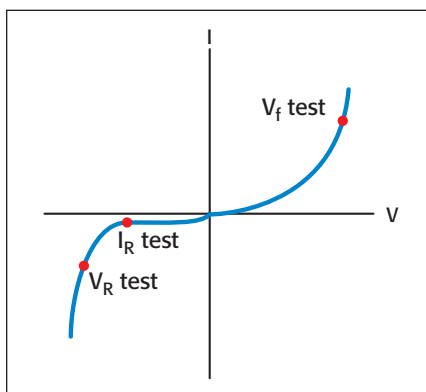

Figure 2: Production testing of diodes involves measurements of forward voltage, reverse breakdown voltage, and leakage current.

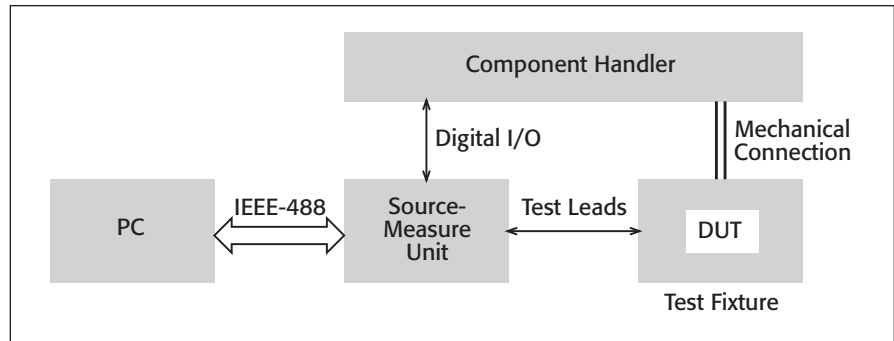

Figure 3: In this test the diodes arrive with unknown polarity, but the component handler can rotate them if necessary before testing.

a specified minimum limit to determine the pass/fail status of the test. Leakage current, I_R , also sometimes called reverse saturation current, I_S , is the current that flows when a reverse voltage less than the breakdown voltage is applied to the diode. It is measured by applying a specified reverse voltage and measuring the resulting current. A program is written to set up the diode tests in the memory location of the source/memory instruments. The tests are then executed from one trigger over the IEEE bus. The instrument steps through the memory locations without computer intervention.

We will assume a test setup in which the diodes arrive with unknown polarity, but the component handler can rotate them if necessary before testing (Figure 3). The test steps are as follows:

1. The operator indicates to the PC that a diode production lot is in place and ready for test.
2. The PC preconfigures the tests that the SMU will perform on each diode via GPIB.
3. The SMU waits for Start of Test trigger from the handler.
4. When the first diode is in position, the handler sends a Start of Test trigger signal to the SMU, indicating first diode is ready for testing.
5. The SMU executes a polarity test. If the diode is in forward polarity, the SMU proceeds with functional tests (step 6). If in reverse polarity, a signal is sent to the handler to turn the device and return to step 4.
6. Once the diode is in forward polarity, the SMU runs diode functional tests in the order stored in source memory, makes pass/fail determinations and saves data

for each test: Forward Voltage Test, Breakdown Voltage Test, and Leakage Current Test.

7. The SMU sends an overall pass/fail code and End of Test signal to the handler and simultaneously sends test data to the PC via GPIB.
8. Steps 3–7 are repeated for the remainder of diodes in the lot.
9. The SMU returns to the idle state. The operator installs a new lot of diodes in the handler.
10. Steps 1–9 are repeated as required.

Note that the GPIB communication occurs only before and after the actual testing.

RF Power Transistor Tests

While there are many types of RF transistors available, we will use the heterojunction bipolar transistor (HBT) for our examples. Analogous tests apply to other devices. Since transistors are three-terminal devices, two SMUs are generally used. Figure 4 shows two SMUs connected to the device, the first between the HBT base and the emitter and the second between the collector and the emitter. To acquire collector family curves from the HBT, the base SMU is set to output current and measure voltage. The collector SMU is set to sweep voltage and measure current. After the first base current is set, the collector voltage is swept while the collector current is measured. Then the base current is stepped up and the collector voltage is swept again while collector current is measured. This process is repeated until all the collector I-V curves at the different base current levels are acquired.

Synchronizing the Instruments

Since it is desirable for both instruments

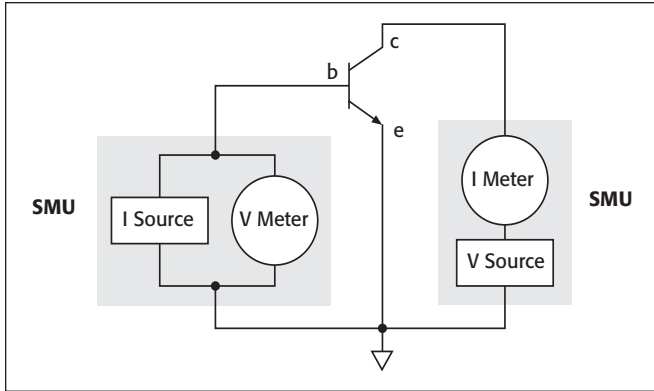

Figure 4: In transistor testing two SMUs are generally used, the first connected between base and the emitter and the second between collector and emitter.

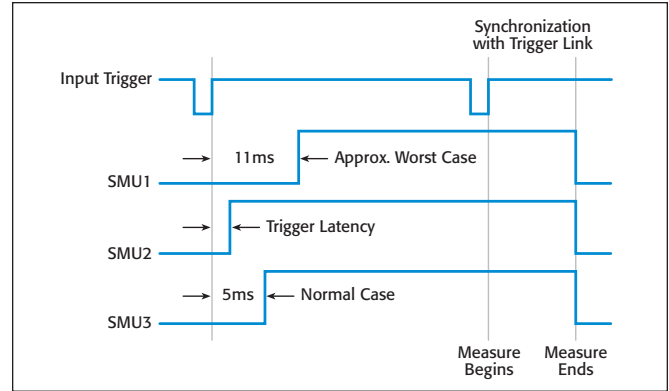

Figure 5: Synchronization of the triggering keeps tests running in the correct sequence.

to be preprogrammed (and thus avoid GPIB delays), we would like all the instruments in the setup to operate synchronously. At first this would not appear to be a problem: If several SMUs, for example, all have the same firmware and are programmed with same test parameters, the execution times for each step should be the same. The difficulty comes from the memory location recall and auto-ranging steps, which take an indeterminate amount of extra time (See Table 1).

Table 1. Parameter change execution time.

Description	Approximate Execution Time (ms)
Changing current range	5
Changing voltage range	5
Switching from I source to V source*	11 (worst case)

* Switching source mode requires that the output be turned off and often requires changing both the voltage and current ranges.

In cases like this an external, dedicated trigger controller should be used to make sure that the measurement occurs at the same time for multiple instruments. It's especially useful when a test system is built using equipment from different manufacturers or even products from the same manufacturer with different methods of triggering. The trigger controller takes the guesswork out of learning the nuances involved in operating each piece of instrumentation.

The process works as follows. Although the specific examples refer to Keithley instruments, analogous methods can be used with equipment from other manufacturers.

1. The trigger controller outputs a trigger that is received by all instruments (source input).
2. A Source Memory location is recalled from memory.
3. The source output is enabled on all instruments.
4. Each instrument performs the user-defined delay.
5. Each instrument outputs a trigger to the controller once the delay operation is complete.
6. The trigger controller waits for a trigger output from each instrument (delay output).
7. The trigger controller outputs a trigger that is received by all instruments (measure input).
8. Each instrument begins the measurement operation.
9. Each instrument outputs a trigger to the controller once the measurement is complete.
10. The trigger controller waits for a trigger output from each instrument (measure output).
11. Go to Step 1 to begin the next test.

Figure 5 shows the result of synchronization of the triggering.

Specific Transistor Tests

Breakdown Voltage—Two important breakdown voltages are commonly measured for an HBT. The first is collector-emitter breakdown voltage, which can be measured with base open or shorted. Figure 6a shows the setup to measure the collector-emitter breakdown voltages with base open (BV_{CEO} or $V_{(BR)CEO}$), while Figure 6b

shows the setup with base shorted (BV_{CES} or $V_{(BR)CES}$). The next breakdown voltage is the collector-base breakdown voltage (BV_{CBO} or $V_{(BR)CBO}$), which is commonly measured with emitter open. Figure 6c shows the test setup. In these measurements, the source

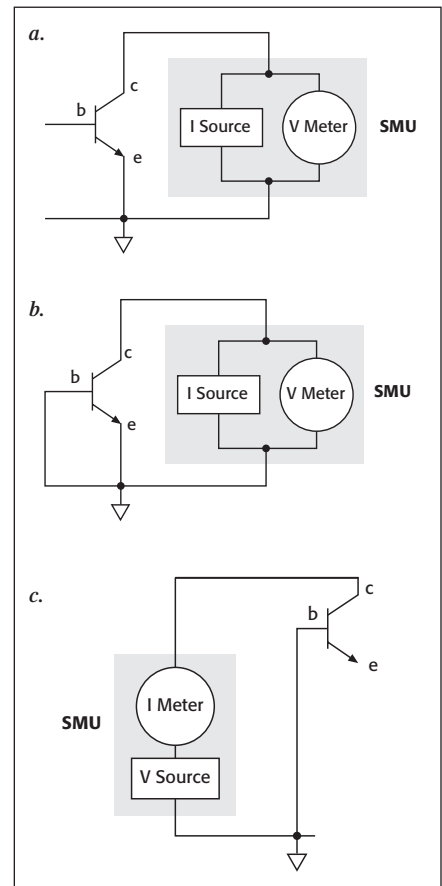

Figure 6: a: Collector-emitter breakdown with base open; b: Collector-emitter breakdown with base shorted; c: Collector cutoff current, $ICBO$, and collector-base breakdown voltage are measured with emitter open

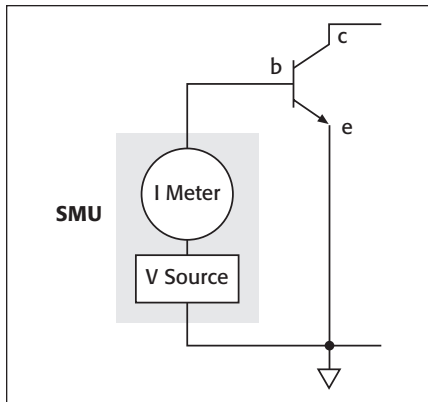

Figure 7: BV_{EBO} and IE_{BO} are measured with collector open.

measure unit sweeps voltage across the HBT while simultaneously measuring current. The current will remain fairly constant until the breakdown voltage is reached, at which point the current increases suddenly.

Other parameters commonly measured on RF power transistors are collector-emitter sustaining voltage, $BV_{CEO(sus)}$ or $V_{CE(sus)}$, collector-emitter breakdown voltage with reverse bias applied to the base-emitter junction, BV_{CEV} or BV_{CEX} , and emitter-base breakdown voltage with collector open, BV_{EBO} (Figure 7).

Junction Leakage Current

Characterizing the off leakage current of the device is also very important, because this leakage current will waste power while the device is not operating and will shorten the operating time of a portable, battery-powered device. The most often measured leakage current parameter is the collector cutoff current, I_{CBO} , which is measured between collector and base, with the emitter open (Figure 6c). The base reverse bias

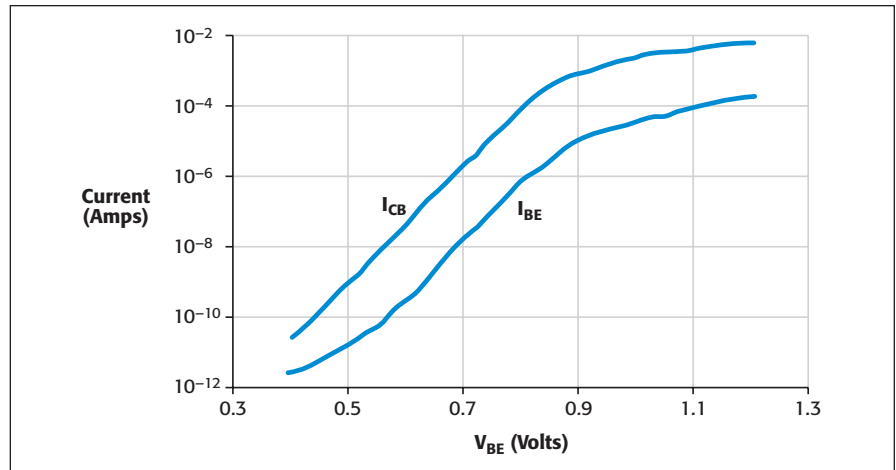

Figure 8: The DC gain can be measured by sweeping the base and collector voltage while simultaneously measuring the base and collector current. After the measurements are complete, the base and collector currents are plotted on a semi-logarithmic scale to produce a Gummel plot. DC gain (β), base and collector ideality factors, series resistances, and more can be extracted.

leakage, also called emitter cutoff current or emitter-base cutoff current, I_{EBO} , is another important leakage current measurement. It demonstrates the base leakage when the device is turned off. Figure 7 shows the measurement setup.

DC Current Gain

The DC gain of an RF power amplifier is very closely linked to its RF gain. It can be measured directly and quickly by sourcing a base current and measuring the corresponding collector current, as shown earlier. Another technique that is often used is to sweep the base and collector voltage while simultaneously measuring the base and collector current. After the measurements are complete, the base and collector currents are plotted on a semi-logarithmic scale to produce a so-called Gummel plot (Figure 8). A number of useful parameters can be extracted from the Gummel plot, including DC gain

(β), base and collector ideality factors, series resistances, and more.

Conclusion

Test throughput can have a significant effect on profitability for manufacturers of semiconductor devices. Knowledgeable use of the programmability of today's multi-function instruments can go a long way toward reducing test costs and improving manufacturing productivity. [KEITHLEY](#)

About the Author

Mary Anne Tupta is a senior applications engineer at Keithley Instruments, Inc., 28775 Aurora Road, Cleveland, Ohio, 44139. Contact her via e mail at: mtupta@keithley.com or call 440-248-0400.

Specifications are subject to change without notice.

All Keithley trademarks and trade names are the property of Keithley Instruments, Inc. All other trademarks and trade names are the property of their respective companies.



Keithley Instruments, Inc.

28775 Aurora Road • Cleveland, Ohio 44139 • 440-248-0400 • Fax: 440-248-6168
1-888-KEITHLEY (534-8453) • www.keithley.com

© Copyright 2004 Keithley Instruments, Inc.
Printed in the U.S.A.

No. 2513
0304